

# Series 775

## Double Check Valve Assemblies

Sizes: 1/2" - 2" (15-50mm)

- Installation
- Service
- Repair Kits
- Maintenance

For field testing procedure, send for IS-TK-DL, IS-TK-9A, IS-TK-99E AND IS-TK-99D.

For other repair kits and service parts, send for PL-RP-BPD.

For technical assistance, contact your local Watts representative.

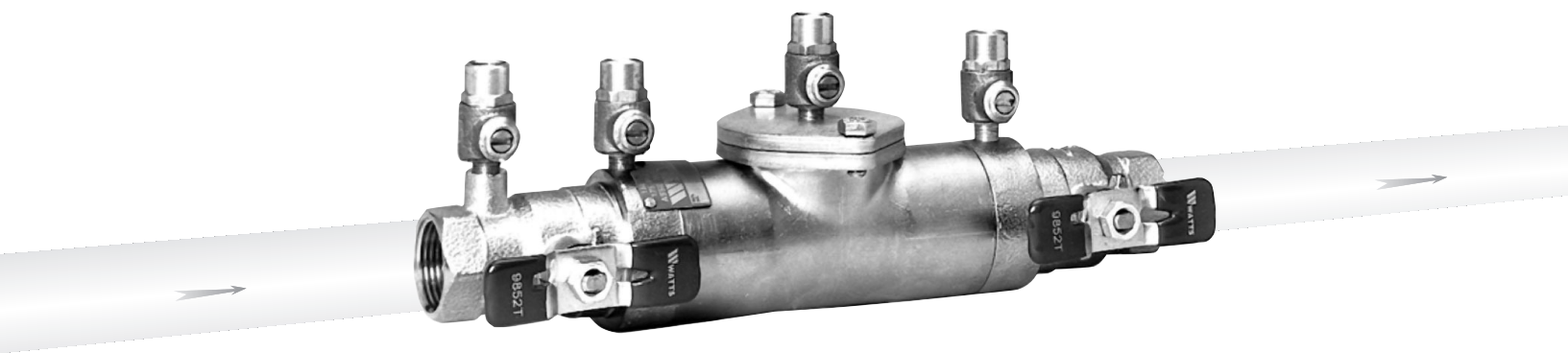

Watts 775QT Size: 3/4"

#### CALIFORNIA PROPOSITION 65 WARNING

**WARNING:** This product contains chemicals known to the State of California to cause cancer and birth defects or other reproductive harm. (California law requires this warning to be given to customers in the State of California.)

For more information: [www.watts.com/prop65](http://www.watts.com/prop65)

**Limited Warranty:** Watts Regulator Co. (the "Company") warrants each product to be free from defects in material and workmanship under normal usage for a period of one year from the date of original shipment. In the event of such defects within the warranty period, the Company will, at its option, replace or recondition the product without charge.

**THE WARRANTY SET FORTH HEREIN IS GIVEN EXPRESSLY AND IS THE ONLY WARRANTY GIVEN BY THE COMPANY WITH RESPECT TO THE PRODUCT. THE COMPANY MAKES NO OTHER WARRANTIES, EXPRESS OR IMPLIED. THE COMPANY HEREBY SPECIFICALLY DISCLAIMS ALL OTHER WARRANTIES, EXPRESS OR IMPLIED, INCLUDING BUT NOT LIMITED TO THE IMPLIED WARRANTIES OF MERCHANTABILITY AND FITNESS FOR A PARTICULAR PURPOSE.**

The remedy described in the first paragraph of this warranty shall constitute the sole and exclusive remedy for breach of warranty, and the Company shall not be responsible for any incidental, special or consequential damages, including without limitation, lost profits or the cost of repairing or replacing other property which is damaged if this product does not work properly, other costs resulting from labor charges, delays, vandalism, negligence, fouling caused by foreign material, damage from adverse water conditions, chemical, or any other circumstances over which the Company has no control. This warranty shall be invalidated by any abuse, misuse, misapplication, improper installation or improper maintenance or alteration of the product. Some States do not allow limitations on how long an implied warranty lasts, and some States do not allow the exclusion or limitation of incidental or consequential damages. Therefore the above limitations may not apply to you. This Limited Warranty gives you specific legal rights, and you may have other rights that vary from State to State. You should consult applicable state laws to determine your rights. **SO FAR AS IS CONSISTENT WITH APPLICABLE STATE LAW, ANY IMPLIED WARRANTIES THAT MAY NOT BE DISCLAIMED, INCLUDING THE IMPLIED WARRANTIES OF MERCHANTABILITY AND FITNESS FOR A PARTICULAR PURPOSE, ARE LIMITED IN DURATION TO ONE YEAR FROM THE DATE OF ORIGINAL SHIPMENT.**

**IMPORTANT:** Inquire with governing authorities for local installation requirements.

**WATTS®**

# Installation Instructions

## Series 775 Double Check Valve Assemblies

### Indoors - Figure 1

Check local codes for installation requirements. Pipe lines should be thoroughly flushed to remove foreign material before installing the unit. A strainer should be installed as shown, ahead of backflow preventer to prevent disc from unnecessary fouling. Install valve in the line with arrow on valve body pointing in the direction of flow.

For indoor installations, it is important that the valve be easily accessible to facilitate testing and servicing. Do not install in a concealed location.

**CAUTION:** Do not install with strainer when backflow preventer is used on seldom-used water lines which are called upon during emergencies, such as fire sprinkler lines, etc. It is important that Series 775 be tested periodically in compliance with local codes, but at least once a year or more often depending upon system conditions. Regular inspection, testing and cleaning assures maximum life and proper product function.

**NOTE: Fire Protection System Installations:**

The National Fire Protection Agency (NFPA) Guidelines require a confirming flow test to be conducted whenever a "main line" valve such as the shutoff valves or a backflow assembly have been operated. Certified testers of backflow assemblies must conduct this test. The trim valves of the confirming flow test. When the test is completed the trim valves must be returned to a fully open position.

### Outside - Figure 2

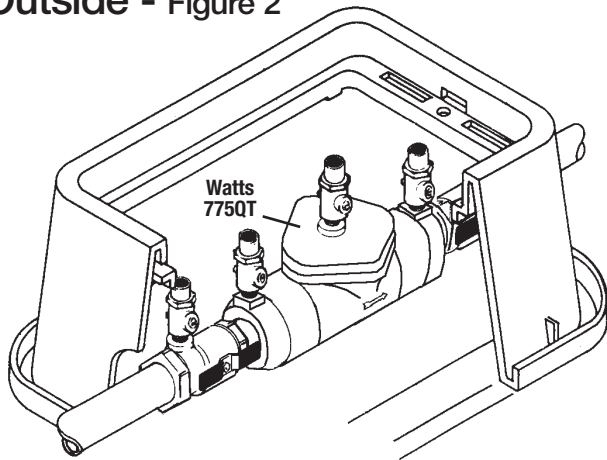

Meter Box Installation

### Parallel - Figure 3

Two or more Series 775 smaller size valves may be piped in parallel (where approved) to serve a larger supply pipe main. This type of installation is employed whenever it is vital to maintain a continuous supply of water/where interruptions for testing and servicing would be unacceptable. It also has the advantage of providing increased capacity where needed beyond that provided by a single valve and permits testing or servicing of an individual valve without shutting down the complete line. For two valve installations the total capacity of the devices should equal or exceed that required by the system. The quantity of valves used in parallel should be determined by the engineer's judgement based on the operating conditions of a specific installation.

Figure 1

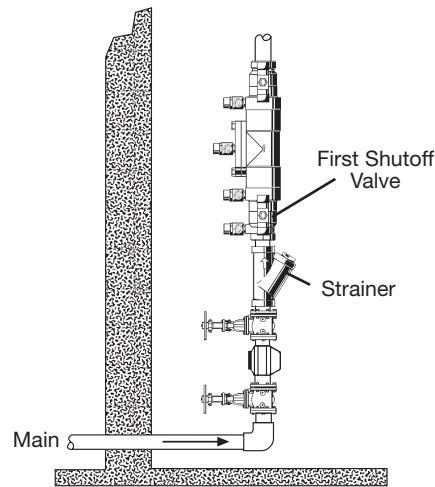
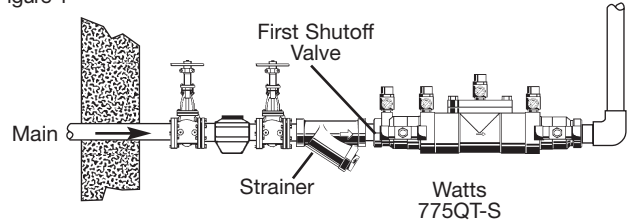

Watts 775QT-S Vertical Flow-up or Vertical Flow-down installation (Flow-up shown)

Figure 2

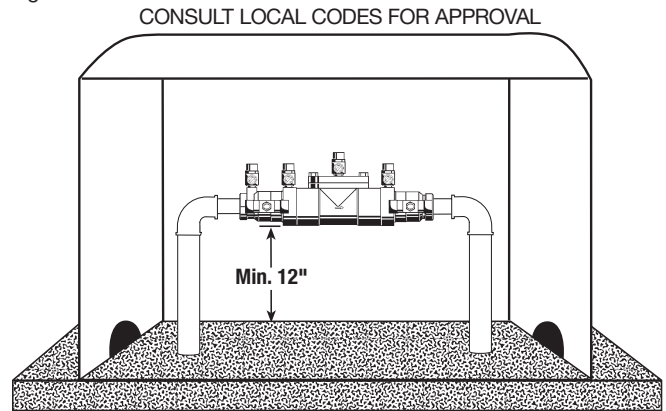

Fiberglass WattsBox

Now Available, WattsBox and PolyRock Enclosures.

For more information, send for literature ES-WB or S-PolyRock.

Figure 3

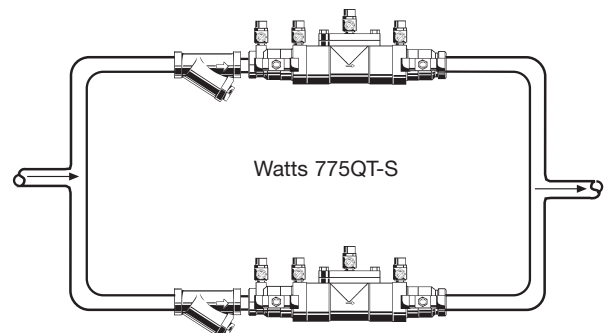

# Service, Replacement Parts and Maintenance

## Servicing the First and Second Check Valves

**NOTE:** Before servicing be certain water is turned off or shutoff valves are closed

1. Close shutoff valves and open test cocks No. 2, 3 and 4 to relieve pressure from the body of the valve. Loosen cover bolts and remove cover. The check valve modules can now be removed from the valve by hand or with a screwdriver. Note: The first and second check assemblies are not interchangeable and the first check assembly must be removed prior to removing the second check assembly.
2. The check assemblies are threaded into the body. To remove the first check assembly, rotate the check module by hand counterclockwise.
3. The second check assembly is removed by inserting the blade of a screwdriver into two opposing slots of the seat as shown in Figure 1 and rotating the check assembly counterclockwise.
4. The check seats are attached to the cage with a bayonet type locking arrangement. Holding the cage in one hand, push the seat inward and rotate clockwise against the cage. The seat, cage, spring and disc assembly are now individual components.
5. The disc assembly may now be cleaned and reassembled or, depending on its condition, it may be replaced with a new assembly from a repair kit. Seat O-rings should be inspected and replaced as necessary.
6. Reassemble the check module in the reverse order. Install the check modules into the valve body hand-tight. Replace the cover.

## 1/2" - 2" (15-50mm) Replacement Parts

When ordering, specify ordering code number, kit number and valve size

### 1st Check Kits

ORDERING CODE	KIT NO.	SIZE	
		in.	mm
0888560	RK 775 CK1	1/2 - 3/4	15-20
0888561	RK 775 CK1	1	25
0888562	RK 775 CK1	1 1/4 - 1 1/2	32-40
0888563	RK 775 CK1	2	50

**Kit includes:** First check assembly and Cover O-ring.

### 2nd Check Kit

0888564	RK 775 CK2	1/2 - 3/4	15-20
0888565	RK 775 CK2	1	25
0888566	RK 775 CK2	1 1/4 - 1 1/2	32-40
0888567	RK 775 CK2	2	50

**Kit includes:** Second check assembly and Cover O-ring.

### Complete Rubber Parts

0888568	RK 775 RT	1/2 - 3/4	15-20
0888569	RK 775 RT	1	25
0888570	RK 775 RT	1 1/4 - 1 1/2	32-40
0888571	RK 775 RT	2	50

**Kit includes:** Cover O-ring, Two discs assemblies and two seat O-rings.

### Cover Kit

0888572	RK 775 C	1/2 - 3/4	15-20
0888573	RK 775 C	1	25
0888574	RK 775 C	1 1/4 - 1 1/2	32-40
0888575	RK 775 C	2	50

**Kit includes:** Cover and Cover O-ring.

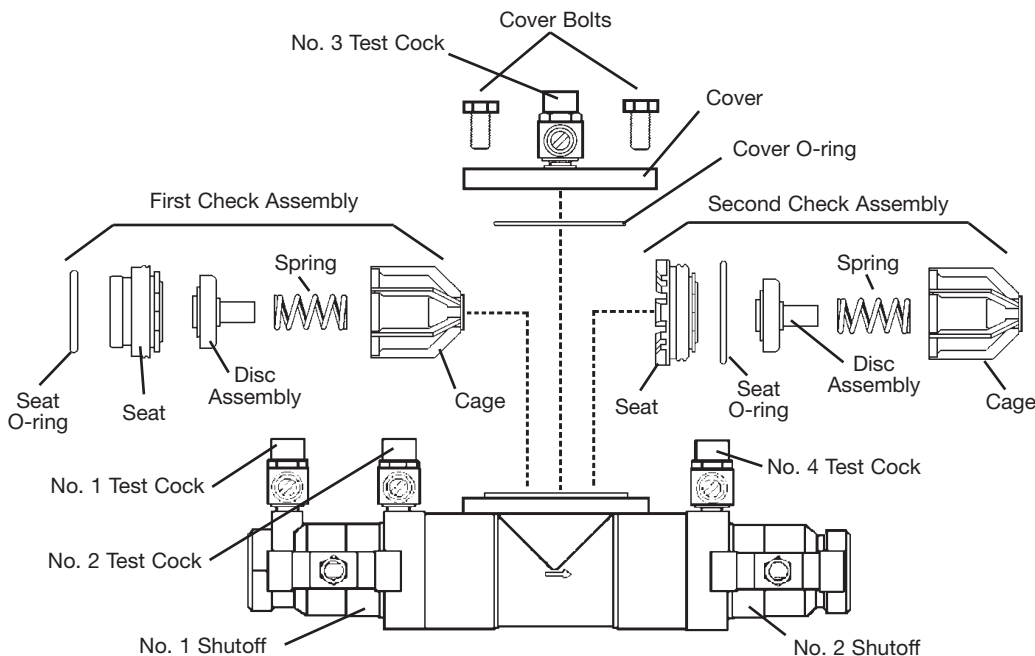

2nd Check Removal

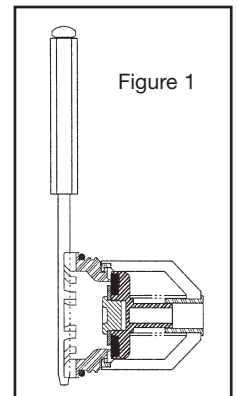

# Test Procedure

## Double Check Valve Assemblies

### Test Check Valve No. 1

- Step 1:** Ensure shutoff #1 is open, shutoff #2 is closed.
- Step 2:** Connect high side hose to test cock #3, low side to test cock #2 and open both test cock #2 and test cock #3.
- Step 3:** Open valve C, then open A to bleed air from the high side. Close valve A, then open B to bleed low side. Close valve B.
- Step 4:** Connect vent hose loosely to test cock #1. Open valve A to vent air from vent hose, Tighten vent hose at test cock #1, open test cock #1.
- Step 5:** Close shutoff #1. Slowly loosen hose at test cock #2 until differential gauge rises to 2 pre-tighten hose. If the differential reading does not decrease, record check valves as "tight".

### Test Check Valve No. 2

- Step 1:** Move the high side hose to test cock #4, low side to test cock #3 and open both test cock #3 and test cock #4. Remove vent hose from test cock #1, open shutoff #1.
- Step 2:** Open valve C, then open valve A to bleed air from the high side. Close valve A, then open valve B to bleed low side. Close valve B.
- Step 3:** Connect vent hose loosely to test cock #1. Open valve A to vent air from the vent hose, Tighten vent hose at test cock #1, open test cock #1.
- Step 4:** Close shutoff #1, and then slowly loosen hose at test cock #3 until differential gauge rises to 2psi and retighten hose. If the differential reading does not decrease, record check as tight. Remove all hoses and restore valve to original working condition.
- Note:** The assembly will fail both the first and second check valve tests above, if shutoff #2 leaks excessively. To test for a leaky #2 shutoff, use the following procedure.

### Test for Leaky No. 2 shutoff

- Step 1:** Connect the high side to test cock #1, low side to test cock #4. Open test cock #1 and test cock #4. Close shutoffs #1 and #2.
- Step 2:** Close valve C. Open valve A, then open valve B 1.2 turn, loosen hose at test cock #4 to remove air. Retighten hose.
- Step 3:** If the differential gauge rises above 0, there is excessive leakage at shutoff #2 and it must be replaced to test the assembly.

**Note:** Product information is subject to change without notice and supersedes all previous publications

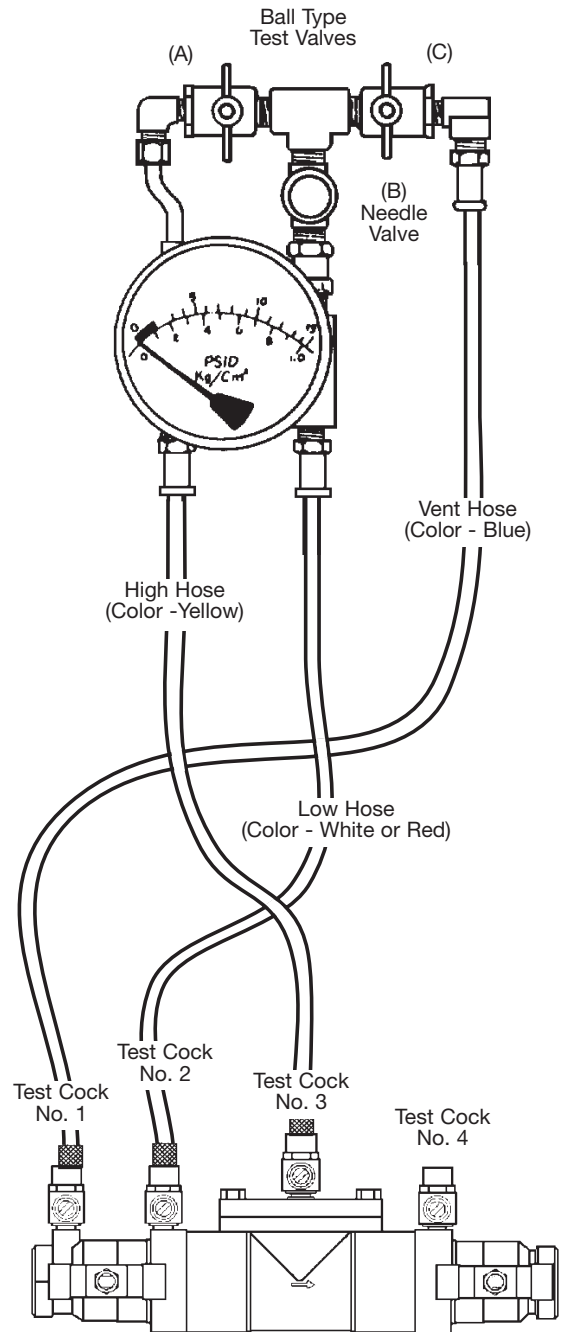

# WATTS®

Backflow Prevention Products

ISO 9001-2000  
CERTIFIED

USA: 815 Chestnut St., No. Andover, MA 01845-6098; www.watts.com

Canada: 5435 North Service Rd., Burlington, ONT. L7L 5H7; www.wattscanada.ca